

# A Review on Turbo Codes for Error Detection and Correction in Wireless Networks

Farheen Qureshi<sup>1</sup>, Prof. Shailendra Bhalla<sup>2</sup>

*Department of CSE, SDBCT, Indore<sup>1,2</sup>*

Date of Submission: 10-06-2023

Date of Acceptance: 20-06-2023

**ABSTRACT:** Wireless networks are undergoing a paradigm shift with emergence of high performance internet of things (IoT). The demand for bandwidth has significantly risen due to multimedia applications and high speed data transfer. Due to the large data speeds and wireless nature of the channel, error detection and correction measures are indispensable for high trustworthiness in networks. This paper presents a comprehensive review on need of error detection and correction in wireless networks and the related work done in the domain. The emphasis has been laid on the error detection and correction employing the turbo encoding mechanism. The turbo encoding mechanism has been chosen as the baseline technique as it shows adherence to the Shannon's limit while exhibiting a steep plummet in the error rate, in the error rate even at low SNR values. The important features of the turbo encoding-decoding process has been cited with explanations. A review of the various categories of turbo codes and similar approaches has been presented. Salient features of contemporary work have been cited.

**Keywords:** Internet of Things (IoT), Error Detection and Correction, Trustworthiness, Turbo Codes, Shannon's Limit.

## I. INTRODUCTION

Internet of things has emerged as new paradigm with enormous new possibilities such as

metaverse, digital clones, large scale automation and internet of things to name a few [1]. However, all these new age concepts critically depend on the bandwidth availability and spectrum management in wireless networks. As bandwidth is limited, hence, effectively using the bandwidth is critically important to cater to the following needs [2]:

- 1) Increasing number of users.
- 2) Increased bandwidth requirement owing to multimedia data transfer.
- 3) Need for high data rates.
- 4) Limited available bandwidth.

The problem becomes even more critical with the necessity of internet of things (IoT) and fog computing networks where multiple devices are connected over internet and send data to a centralized server [3]. The IoT framework is depicted in figure 1.

There are several applications of IoT such as:

- 1) Manufacturing and automation.
- 2) Climate monitoring.
- 3) Communications and robotics.
- 4) Defense
- 5) Medical applications etc.

The IoT framework is finding exceeding applications due to the scalability and mobility advantage in wide area networks especially for time critical automation applications. Figure 1 depicts the IoT framework.

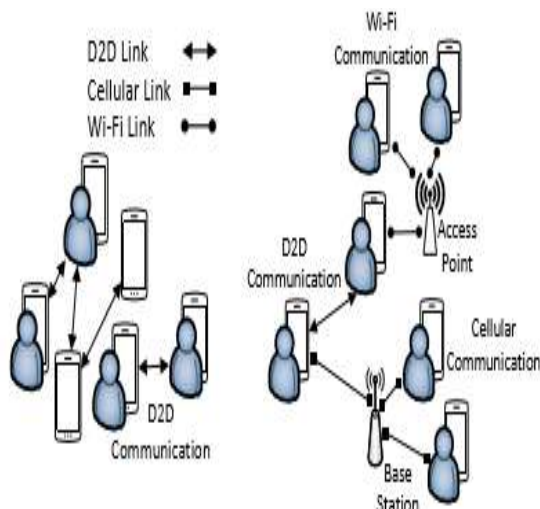

**Fig.1 The IoT framework**

The IoT framework has its own set of limitations in the sense that that is a lot of device cluttering in the near 2.4GHz Industrial scientific and medical (ISM) band. IoT based networks can be further classified as [4]:

- 1) Cellular based IoT
- 2) Device to Device based IoT.

Figure 2 depicts the D2D and Cellular based IoT models.



**Fig.2 Standalone and Network assisted IoT.**

Another variant of the IoT framework is the fog computing architecture for last mile connectivity. The IoT networks are often limited by bandwidth and data processing constraints. Another method with is similar to the IoT

framework but includes last mile connectivity of devices is termed as the fog computing architecture[5].The fog computing architecture is depicted in figure 3.

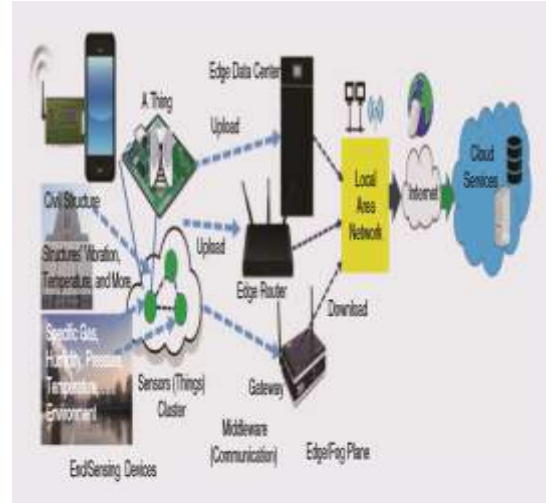

**Fig.3 The fog architecture**

## II. NEED FOR ERROR DETECTION AND CORRECTION

The internet of things can be considered to be the combination of the following frameworks:

- 1) Sensing nodes for data.
- 2) Processing units.
- 3) Memory elements.
- 4) Routers and switches.
- 5) Transceivers.
- 6) Position monitoring and relocation systems.

As the IoT framework may comprise of simple to sophisticated devices with varying amounts of memory and processing power, hence it is necessary to authenticate and monitor the type of data to be transmitted and received by the entire network [6]. Generally, the IoT network is a wide area network with a lot of devices and routers connected through the internet. The fundamental mode of transfer of data in the IoT or Fog network is unguided media. While unguided media has the advantages of lower cabling costs, ease of mobility and scaling, it is severely affected by the noise and disturbance effects in the unguided media of free space. Hence it is necessary to monitor and check the error in the bits which are transmitted and received in the IoT framework [7].

One of the ways to do the same is the design of error detection and correction codes which are able to pick up the errors in the received data at the receiving end and also able to correct them. Of several mechanisms to correct the errors,

one of the most potent coding techniques is the turbo encoding mechanism [8]. The turbo encoding mechanism exhibits extremely good error plummeting performance in the waterfall region of the error rate curve analysis with steep fall in the error rates even for low value of signal to noise ratio. This is typically useful for IoT and Fog frameworks as the devices are often constrained in terms of the processing power leading to limited encoding options and also as the media is unguided, the path loss factor results in the reduction in the signal strength resulting in the low value of signal to noise ratio. The double whammy exists in the case of high noise and disturbance effects in the channel leading to distortions in the received SNR values. Thus a fall in the error rate for lower values of SNR in the case of turbo decoding is extremely useful and makes the technique feasible for application in real time applications [9].

Without loss of generality, it can be stated that Turbo Codes are very close to Shannon's limit mathematically defined as [10]:

$$C = B \log_2 \left( 1 + \frac{S}{N} \right) \quad (1)$$

Here,  
 C is channel capacity  
 S is signal power  
 N is noise power  
 B is bandwidth

The Shannon's limit is BER of almost  $10^{-5}$  (ideally 0)

for  $\frac{E_b}{N_0} = 0$  dB for binary modulation. [10]

A typical example where the turbo encoder and decoder are used is depicted in the Fig.1:

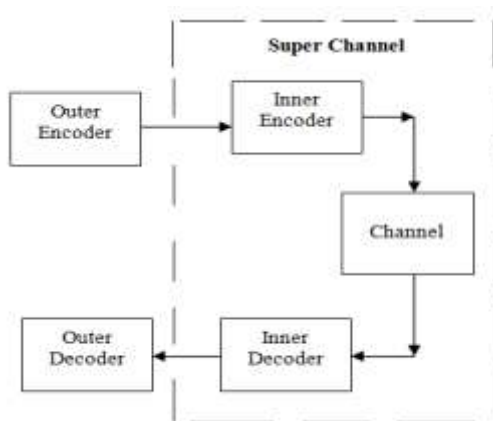

Fig.4 Encoder-Decoder Structure

### a. Turbo Encoding

The turbo encoding can be thought of as a two-step process comprising of the inner encoder and the outer encoder.[11] The inner encoder, channel and outer encoder is often termed as the super channel. Fig.2 exhibits the structure of the coding mechanism. The above limit corresponds to a binary rate  $R=1/2$  convolution encoder which has a constraint length  $K$  and memory  $M=K-1$ .

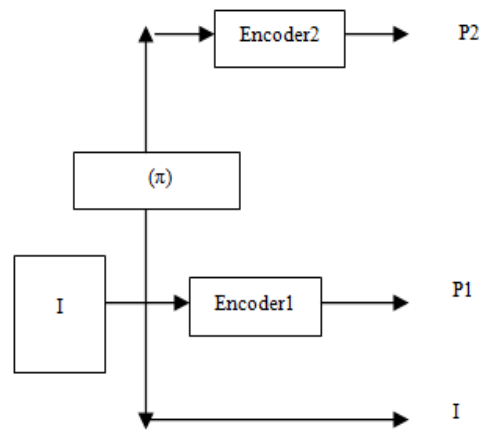

Fig.5 Structure of Turbo Code Encoder

The turbo encoding can be thought of as a two-step process comprising of the inner encoder and the outer encoder.[12]. The inner encoder, channel and outer encoder is often termed as the super channel. The encoder may have to identical encoding blocks which result in the system being termed as a symmetric encoding structure [13]. The essence of the encoding approach lies in the fact that there are two encoders generating two parallel parity bit streams. Additionally, the unaltered bit stream which is the actual data is also transmitted. The parity bits P1 is the output of the encoder 1 while the parity bit P2 is the output of the encoder 2. The interleaver is responsible for the re-arrangement of the bits (information bits) prior to feeding the encoder 2. Thus three parallel bit streams are generated which passes through the channel and the decoder has the job of identifying the actual bit stream with an accurate guess so as to manage low values of error rate at the decoding end and this would lead to high trustworthiness in the system [14].

Assuming that the bit  $d_k$  is the input to the encoder at time  $k$ , we have the codeword  $C_k$  which is binary coupled:[2]

$$X_k = \sum_{i=0}^{k-1} g_{1_i} d_{k-1} \text{ mod. } 2 \quad g_{1_i} = 0, 1 \quad (2)$$

$$X_k = \sum_{i=0}^{k-1} g_{2i} d_{k-1} \text{ mod. } 2 \quad g_{2i} = 0,1 \quad (3)$$

Where,

$$G_1: \{g_{1i}\} \quad (4)$$

$$G_2: \{g_{2i}\} \quad (5)$$

G1, G2 are two code generators generally expressed in the octal form.

The Convolutional encoders are used in a parallel structure with an interleaver to introduce randomness [15].

### b. Turbo Decoding

The turbo decoder comprises of two decoders, akin to the encoder to perform the exactly reverse operation. The interleaver is represented by ( $\pi$ ) and the de-interleaver is represented by ( $D\pi$ ) [16]

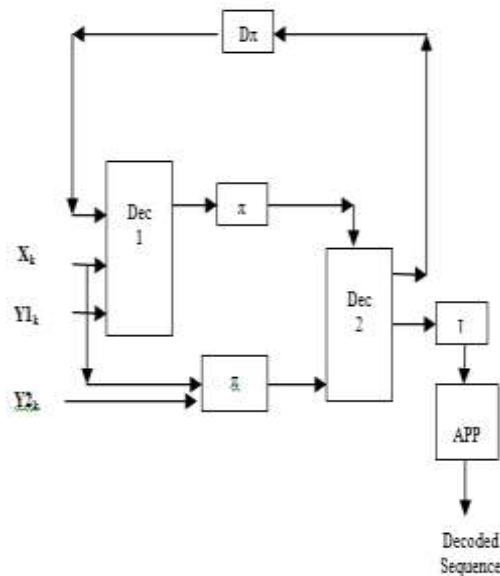

Fig.6 Structure of Turbo Decoder

The different blocks used in the decoding mechanism are:

- 1) Decoding block 1.
- 2) Decoding block 2.
- 3) Interleaver.
- 4) De-Interleaver.
- 5) Aposteriori probability estimator.
- 6) Probability threshold block.
- 7) Information bits.
- 8) Parity bits.

For a random channel, the turbo decoder is made up of the random variables  $x_k$  and  $y_k$  defined mathematically as [17]:

$$x_k = (2d_k - 1) + i_k \quad (6)$$

$$y_k = (2Y - 1) + q_k \quad (7)$$

Here,

$k$  is the time index

$i_k$  and  $q_k$  are independent noises in the channel with noise variance  $\sigma^2$

### III. PREVIOUS WORK

This section presents the salient features of the previous work done in the domain.

**Zhao et al.** proposed a Markov based method with superposition. This would yield the parity generation with recursion (PrBMST-LDPC). The approach was to reduce the complexity of the recursive approach to generate the parity and non-parity bits so as to make it feasible for low complexity implementation.

**Chen et al.** presented about the Polar Codes attracting concern and attention in the recent times. Especially in the forthcoming 5G wireless networks their adoption and use has been garnering attention.

**Moloudi et al.** proposed coding techniques with spatial connection. The codes are concatenated codes with the information bits spatially connected. This is shown to reduce the error rate in the waterfall region.

**Cai et al.** put forth the block Markov superposition transmission of BCH (BMST-BCH) codes, that can be made to get a very low and reduced error floor measure.

**Liva et al.** enunciated the block codes design for the brief data blocks i.e. for less than thousand data bits. It is a problem that has been an active research area that has garnered importance due to latest technical developments in the wireless communication networks.

**Arkan et al.** explained the “turbo revolution” could be considered as successors to the low density parity check (LDPC). The channel coding area has seen a lot of modernization and technical advancements in the recent couple of years. made significant improvement.

**Boulat et al.** proposed a mechanism on encryption based security types. It is useful as it can secure against decoding that is unauthorized. But lesser possibility of interception is mainly ensured by strong communication. model that showed good results.

**Babar et al.** discussed the area of high detection intricacy that has been the chief challenge in the nearby future. The Gigabit frameworks have to be strongly handled and improvised in order work in tandem with other structures and types of domain. Here a quantum based detector can go a

long in getting the outcomes right on time. It can detect signals in the range of hundreds attributing to its parallel working feature. T

#### IV. CONCLUSION:

This paper presents a comprehensive review on the need for trustworthiness in IoT and Fog networks. The introduction to error detection and correction pertaining to the trustworthiness of large scale wireless networks and IoT networks has been presented. Moreover, it has been shown that due to the effectiveness of Turbo Codes and their adherence to Shannon's limit, they are the most suitable for high data rate networks. Previous work and their significant contribution have been cited and explained. This paper paves the path for future advancements in the domain of design of turbo codes for wireless IoT and Fog networks.

#### REFERENCES

- [1] S. Zhao, J. Wen, S. Mumtaz, S. Garg and B. J. Choi, "Spatially Coupled Codes via Partial and Recursive Superposition for Industrial IoT With High Trustworthiness," in IEEE Transactions on Industrial Informatics 2022, vol. 16, no. 9, pp. 6143-6153.
- [2] Chaofan Chen, Li Li, Li Wang, Shuai Wang, Xiangming Li, George K. Karagiannidis, "Noncoherent Detection With Polar Codes", IEEE 2021.
- [3] Saeedeh Moloudi, Michael Lentmaier, Alexandre Graell i Amat, "Spatially Coupled Turbo-Like Codes", IEEE 2020.
- [4] Suihua Cai, Nina Lin, and Xiao Ma, "Block Markov Superposition Transmission of BCH Codes with Iterative Erasures-and-Errors Decoders", IEEE 2019.
- [5] Gianluigi Liva, Lorenzo Gaudio, Tudor Ninacs and Thomas Jerkovits, "Code Design for Short Blocks: A Survey", IEEE 2018.
- [6] Erdal Arkan, Daniel J. Costello, Jr., Joerg Kliewer, Michael Lentmaier, Paul Siegel, Ruediger Urbanke, Michael Pursley, "Guest Editorial Recent Advances in Capacity Approaching Codes", IEEE 2017.
- [7] Boulat A. Bash, Dennis Goeckel, Saikat Guha, Don Towsley, "Hiding Information in Noise: Fundamental Limits of Covert Wireless Communication", IEEE 2016.
- [8] Zunaira Babar, Soon Xin Ng and Lajos Hanzo, "EXIT-Chart Aided Near-Capacity Quantum Turbo Code Design", IEEE 2015.
- [9] Michael Lentmaier, Saeedeh Moloudiy, and Alexandre Graell i Amat, "Braided Convolutional Codes – A Class of Spatially Coupled Turbo-Like Codes", IEEE 2014.
- [10] Tsung-Yi Chen, Kasra Vakili, Dariush Divsalar, and Richard D. Wesel, "Protograph-Based Raptor-Like LDPC Codes", IEEE 2014.
- [11] Claude Berrou, Alain Glavieux and Punya Thitimajshima, "Near Shannon Limit Error Correcting Coding and Decoding: Turbo Codes", IEEE 1993
- [12] www.nptel.ac.in/courses/117105077/courses/channel coding
- [13] S. Vafi, T. Wysocki, and I. Burnett, "Convolutional interleaver for unequal error protection of turbo codes," Joint 7th International Symposium on DSP and Communication Systems (DSPCS) and 2nd Workshop on the Internet, Telecommunications and Signal Processing (WITSP), pp. 485–491, Dec. 2003.
- [14] S. Vafi and T. Wysocki, "Iterative turbo decoder design with convolutional interleavers," 4th international symposium on Communication Systems, Networks and Digital Signal Processing, Newcastle (CSNDSP), UK., pp. 124– 127, July2004.
- [15] S.Vafi and T.Wysocki, "Computation of the free distance and low weight distribution of turbo codes with convolutional interleavers," 15th IEEE International Symposium on Personal, Indoor and Mobile Radio Communications (PIMRC), pp. 1356–1359, September2004.
- [16] S.Vafi and T.Wysocki, "Weight distribution of turbo codes with convolutional interleavers," Submitted to IEEE Proceedings Communications,2005.
- [17] S.VafiandT.Wysocki,"Ontheperformanceofturbo codeswithconvolutional interleavers,"Asia-PacificConferenceonCommunications(APCC),pp.222– 226, October2005.